



Ion-0-Vac Web and Sheet Cleaner

INSTALLATION AND OPERATING INSTRUCTIONS

TABLE OF CONTENTS

1. SAFETY WARNINGS	1
2. DESCRIPTION	3
Options Available for Web Applications	3
Options Available for Sheet Applications (Space Permitting)	3
3. SPECIFICATIONS	4
4. INSTALLATION	5
Vacuum Heads	5
Brush Setting.....	5
Collection System	7
Miscellaneous Items	8
5. OPERATION	10
Wiring.....	10
Prior To Start-Up.....	11
6. MAINTENANCE	12
Vacuum Heads	12
Static Bars.....	12
Flexible Tubing or Ducts	12
Collection System	12
7. TROUBLESHOOTING	13
Static Bar Operational Test	13
D167RY, D267RY, F167, and F267 Power Unit Operational Test	13
Dust Collector.....	14
Ducting Collapsed or Plugged.....	14
Fan Exhaust is Restricted.....	14
Filter is Plugged with Fibrous Material.....	14
8. WARRANTY	15
9. DIMENSIONAL DRAWINGS (for reference only)	16

1. SAFETY WARNINGS



NOTE! Statements identified with a NOTE indicate precautions necessary to avoid potential equipment failure.



CAUTION! Statements identified with a CAUTION indicate minor or moderate injury is possible.



WARNING! Statements identified with a WARNING indicate serious injury is possible.



NOTE! This equipment must be correctly installed and maintained. Adhere to the following notes for safe installation and operation.

1. This equipment must be correctly installed and properly maintained. Adhere to the following cautions for safe installation and operation.
2. Read instruction manual before operating or installing device.
3. Qualified service personnel must do installation and repairs.
4. Ground the frame of the machine on which the power supply and neutralizing bars are mounted.
5. Disconnect supply voltage to power supply before connecting neutralizing bar to the high voltage terminal strip.



CAUTION! Electrical Shock Hazard

1. Do not touch bar when power supply is energized.
2. Disconnect supply voltage to power supply before connecting bar or performing any maintenance to the system.



WARNING! Fire Hazard

Do not install or operate equipment in close proximity to any flammable solvents or flammable materials.

This equipment must be correctly installed and properly maintained as outlined in this manual. Adhere to the following cautions for safe installation and operation:

1. Disconnect and lockout all power before servicing this machine, unless instructions state otherwise. Turn off web drive equipment and remove web, if possible, before performing maintenance.
2. Failure to properly ground the power supply may result in an electrical shock hazard to personnel and inefficient operation of the equipment. Do not apply line power until all grounds and high voltage connections have been completed.
3. Do not pour alcohol on bar or soak bar in alcohol at any time or damage to the inner bar assembly may result.
4. Do not hang rags on static bar or a fire may result
5. To avoid a potential fire hazard caused by sparks in the dust collector, do not mix combustible materials such as buffing lint, paper, wood, dust, aluminum and magnesium with dust generated from grinding ferrous metals.
6. Under no condition should machine operator put a lit cigarette or any burning object into the hood or ducting of the dust control system.

7. When collectors are used to collect dust at risk of fire or explosion, the dust collector should be located outside the building. An individual familiar with fire extinguishing equipment, flammable material hazards and local fire codes should be consulted for installation of the collector and installation of proper fire extinguishing equipment.
8. Explosion relief vents are required on some applications. Consult with an insurance underwriter or a NFPA MANUAL (NFPA 68 Venting Of Deflagrations – NFPA 91 Blower and Exhaust Systems) to determine proper vent size and ratio. Vents installed on dust control equipment within a building must be vented to the outside with ducting that meets the following specifications:
 - Cross sections are no smaller than the vent
 - No longer than 10'
 - Straight with minimal bends (to minimize chances of secondary explosion)
 - Fabricated from 16 gauge (or thicker) sheet steel
9. Consult the proper authorities to determine proper venting methods. Simco-Ion's dust collectors do not contain explosion relief-vents.
10. Consult and comply with all National and Local Fire Codes and/or other appropriate codes when determining the location and operation of dust collection equipment.

2. DESCRIPTION

The Ion-O-Vac Sheet and Web Cleaning System consists of two main assemblies: The vacuum heads and the collection system. For web applications, two vacuum heads are normally required. For sheet applications, one vacuum head is normally sufficient. The vacuum head provides a uniform high velocity air flow at the orifice across the entire width of the material being cleaned. A static eliminator is also provided with web cleaners to remove static prior to the cleaning process. Contaminants removed from the stock surface are carried to the collection system while the transporting air is returned to the plant free of contaminants.

Mark I: Vacuum head with a pair of stationary brushes (one left hand and one right hand) or a pair of chad blades (for noncontact applications) One static eliminator is normally provided to remove static before the cleaning process.



Figure 1. Ion-O-Vac Sheet and Web Cleaning System

Options Available for Web Applications

Adjustable Orifice: If the vacuum heads are to be installed on top of the web with no roller underneath, this option is a must. On narrower web widths, this option will enable the operator to close off the ends of the orifice to avoid losing the vacuum.

Manual or Pneumatic Retraction System: If the vacuum heads are to be installed on top of an idler roller, this option will allow the operator to “swing” or “raise” the vacuum heads for ease of webbing and to allow access to the idler rollers. Note that Pneumatic Retraction Systems utilize air cylinders in place of the standard Micrometer Adjustment feature.

Options Available for Sheet Applications (Space Permitting)

Quick Release Brackets: This option allows the operator to easily remove the vacuum head from the press by simply engaging the quick release pins and sliding the vacuum head away from the impression cylinder.

Canister Collection System: Consists of a regenerative low CFM, high static pressure blower and a collector known as a canister which contains a pre-filter and a filter. This system also features an audible alarm which is activated when the filter needs changing.

3. SPECIFICATIONS

Vacuum System		
Requirements	MK-I: 4.0" of water (min)	
Volume	MK-I: 6.5 cfm per inch of intake	
MEB Static Bar Power Supply		
High Voltage Power Supply	F167 (120 VAC, 50/60 Hz, 0.25A)	F267 (230 VAC, 50/60 Hz, 0.12A)
	NOTE: Maximum 2 static bars or 200" total static bar length can be used with power supply models F167 and F267.	
	D167RY (120 VAC, 50/60 Hz, 0.25A)	D267RY (230 VAC, 50/60 Hz, 0.12A)
	NOTE: Maximum 4 static bars or 200" total static bar length can be used with power supply models D167RY and D267RY	

4. INSTALLATION

Vacuum Heads

For installation of the vacuum head, please refer to the attached installation prints.

Mark I Vacuum Head for Web Applications

Install the vacuum head as shown on the installation print, paying particular attentions to the relative position of the static bar and vacuum head orifice with respect to the direction of the web path. The web should pass under the static bar first (to eliminate static) and then pass under the orifice for cleaning. The vacuum head can be installed on top of an idler roller or web. It is preferable that the vacuum head is installed on top of an idler roller to maintain orifice air velocity. After the vacuum heads are installed, **DO NOT RUN THE MACHINE! PROCEED TO BRUSH SETTINGS.**

Mark I Vacuum Heads for Sheet Applications

Install the vacuum head as shown on the installation print, ensuring that the vacuum head brushes sit about 1/16" off the impression cylinder. After the vacuum head is installed, **DO NOT RUN THE PRESS; PROCEED TO BRUSH SETTINGS.**

Brush Setting

Mark I Vacuum Heads for Web Applications

Before locking all the bolts on mounting brackets, make sure the brushes are set properly to the idler roller or on top of the web. The tip of the bristles should "kiss" the material to be cleaned. Do not shove the brushes against the roller or web; this will just wear out the bristles prematurely. The vacuum head must be adjusted evenly to prevent the vacuum head from jamming in the bracket. Adjust the vacuum head by turning the micrometer adjustment (or the optional pneumatic reaction shaft) until the brush bristles "kiss" the material to be cleaned (Figure 2). Then tighten the adjustment locknuts to secure in place. For vacuum heads supplied with chad blades, adjust the vacuum heads until there is a "1/32" to 1/16" gap between the material to be cleaned and the tip of the chad blades (Figure 3). Then tighten the adjustment locknuts to secure in place. Make sure that the vacuum heads are fastened securely in place. Inch the machine and check for clearance. For vacuum heads with manual or pneumatic retraction systems, retract the vacuum heads and check for clearance. The vacuum heads should not interfere with the normal operation of the web machine. After all clearances are checked, proceed to **COLLECTION SYSTEM.**

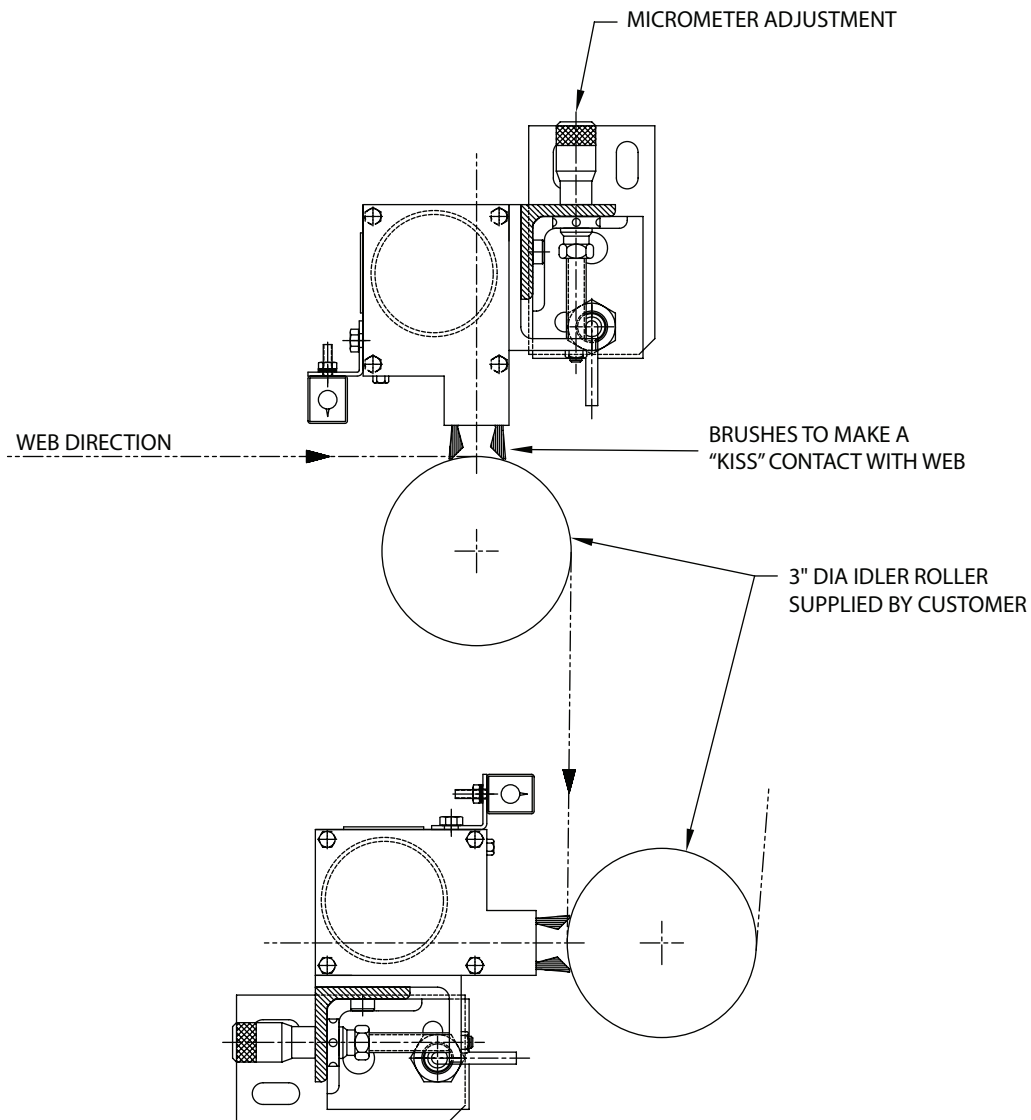

Figure 2. Brush Settings on Mark I Ion-O-Vac



NOTE: Raise or lower the vacuum heads to make sure the brush makes a “kiss contact”.

Mark I Vacuum Heads for Sheet Applications

Lock all bolts in the mounting brackets. All Ion-O-Vacs for sheet-fed presses are designed with micrometer adjustment (see Figure 4). Set the brushes to the impression cylinder as follows:

1. Raise the vacuum head to its highest position with the micrometer adjustment bolts (counterclockwise).
2. Lower the vacuum head with micrometer adjustment bolts evenly (clockwise) until the brushes are about 1/16" off of the impression cylinder.
3. Lock the micrometer adjustment bolts.
4. Inch the press and check for clearance.



NOTE: Raise or lower the vacuum heads until all brushes make a “kiss” contact with the web material.

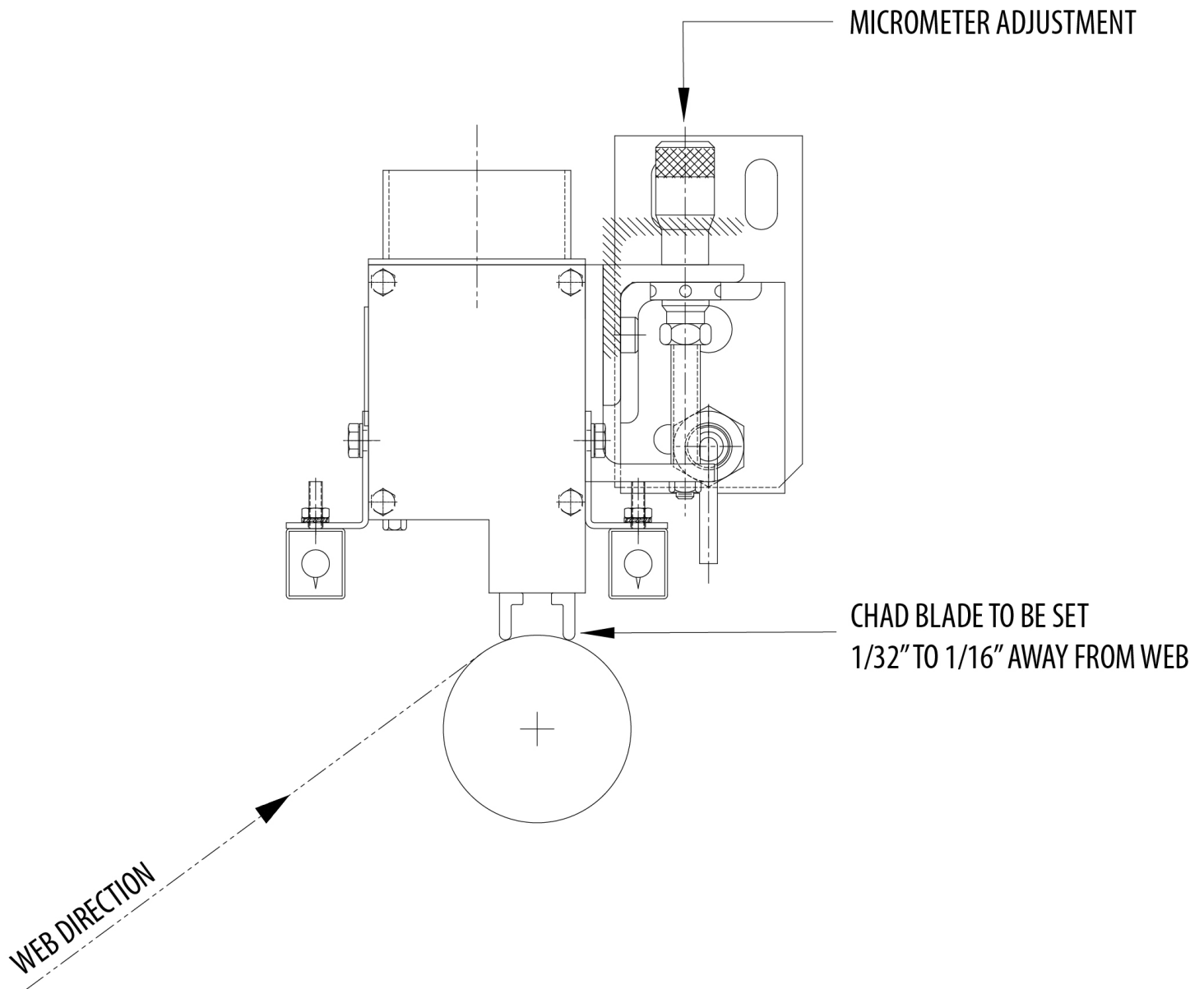

Figure 3. Brush Setting for Mark I Ion-O-Vav with Chad Blades



NOTE: Raise or lower the vacuum heads until the tip of the chad blades are about 1/16" away from the web material.

Collection System

There are five different configurations for the Canister Collection System. The dimensions are shown in the latter part of this manual.

Find a location for your collection system. When finding a location, remember that only 8 feet of flexible ducting is supplied with your equipment. If the collection system is to be located beyond the 8 foot supplied, then use a rigid ducting (PVC type) with glued seams (to avoid loss of the vacuum) avoiding elbows and sharp bends as much as possible. Do not use more than 25 feet of at least 6" diameter additional ducting unless the unit is specifically designed for extensive ducting. Assemble the collection system as shown in the print. For collection systems with sound suppressors, make sure that all the seams have been sealed with silicone (or similar type) to prevent vacuum loss. After collection system is located and assembled, proceed to **MISCELLANEOUS ITEMS**.

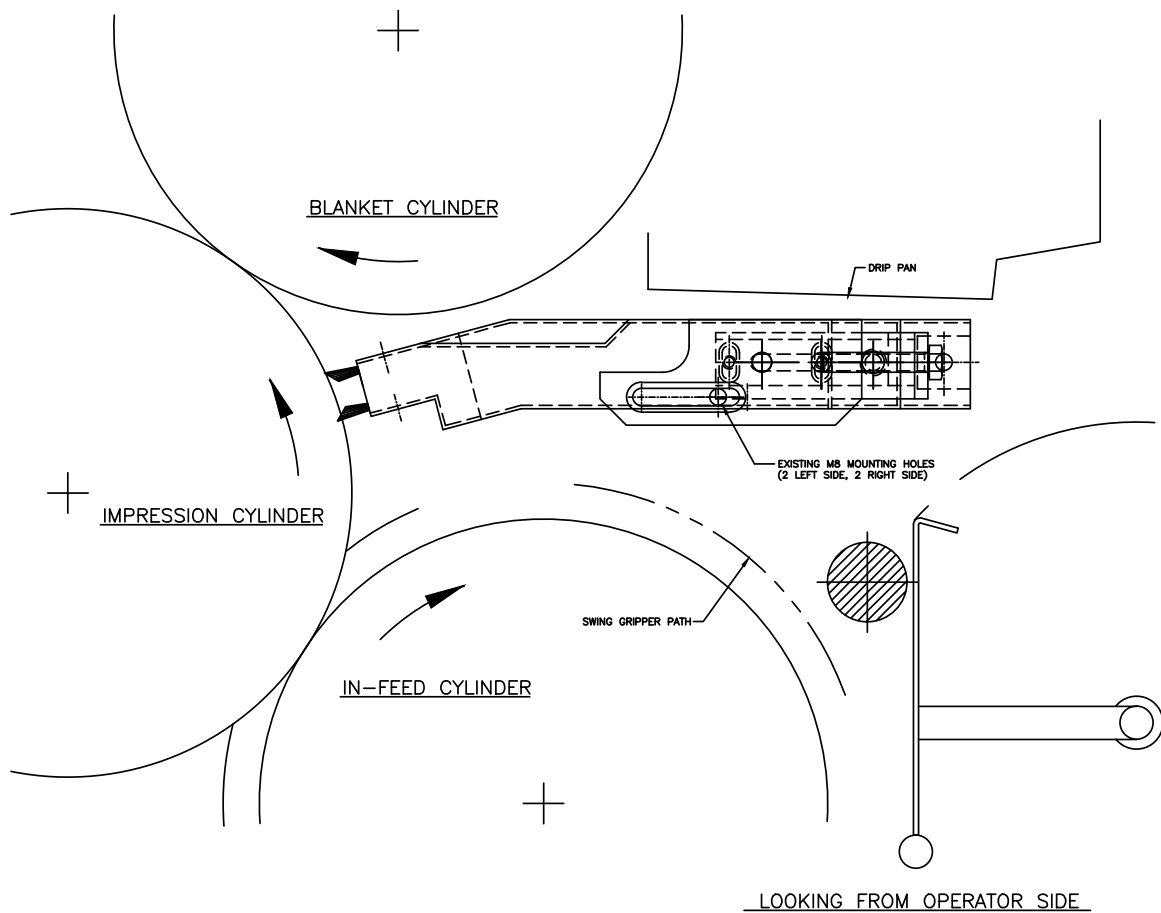

Figure 4. Brush Setting for Mark I Sheet Cleaner



NOTE: Raise or lower the vacuum heads with the micrometer adjustment bolts until the tip of the brushes are about 1/16" off of the impression cylinder.

Miscellaneous Items

Manifold (where applicable)

Install manifold as shown in the installation prints. Make sure that it is fastened securely to the vacuum head and that all joints and seams are sealed with silicone (or similar type) to prevent vacuum loss. Check clearance and ensure that the manifold does not interfere with safety guards and normal operation of the machine. Any dampers or baffles supplied are normally closed for transit.

Flexible Tubing and Ducts

After the manifolds are installed (where applicable) install the 8 foot flexible ducting to the outlet of the vacuum heads and secure in place with hose clamps. Install the other end of the flexible ducting to the inlet of the evacuator and secure with hose clamps. If the evacuator has been located beyond the 8 foot flexible ducting supplied, then use a rigid ducting (PVC type) with glued seams (to avoid vacuum loss), avoiding elbows and bends as much as possible.

Power Supply

The power supply (Model F167 or D167RY) is a transformer that supplies power to the static bars and is normally shipped separately with your equipment. When positioning the power supply, remember that the static bars are normally supplied with a 10 ft. power cable. Locate the power supply in an area free of dirt, oil, water or excessive heat.

Static Bars

Static bars are normally supplied with web cleaners. There are occasions when the static bar is removed from the head to prevent damage during transit. In this case, reinstall the static bar to the vacuum head as per installation prints. For applications with limited space, install the static bar remotely from the vacuum head as per installation print. Install the static bar within 1” of the material to be neutralized. When installing, do not cover emitter points with the clamps. Route the power cable to the power supply, making certain that the cable does not touch any grounded metal machine parts. Use stand-off insulators provided or PVC tubing as necessary. For wiring the static bar to the power supply, refer to Section 5. Wiring.

Compressed Air for Pneumatic Retraction Systems

For Ion-O-Vac with the Pneumatic Retraction System option, the following items will require some assembly; 40 foot air hose, 4-way valve, and filter/regulator. A minimum of 60 PSIG is required to operate the pneumatic retraction system. See print number 202-0042-00 for further instructions on how to route the air hoses and fittings. The control valve is normally located close to the operator for easy access during webbing.



NOTE: Flow control valves are factory set and should not require any adjustment.

5. OPERATION

Wiring

Magnetic Starter and Blower Motor

The magnetic starter is shipped with the overload relay already installed. For wiring instructions for the Siemens' magnetic starter, see Print #202-0041-00. For installation of the Reset Button on a Siemens' magnetic starter, refer to Figure 5.

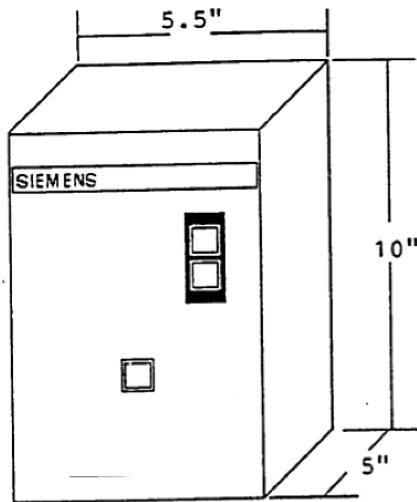

Figure 5. Magnetic Starter General Dimensions (Siemens)

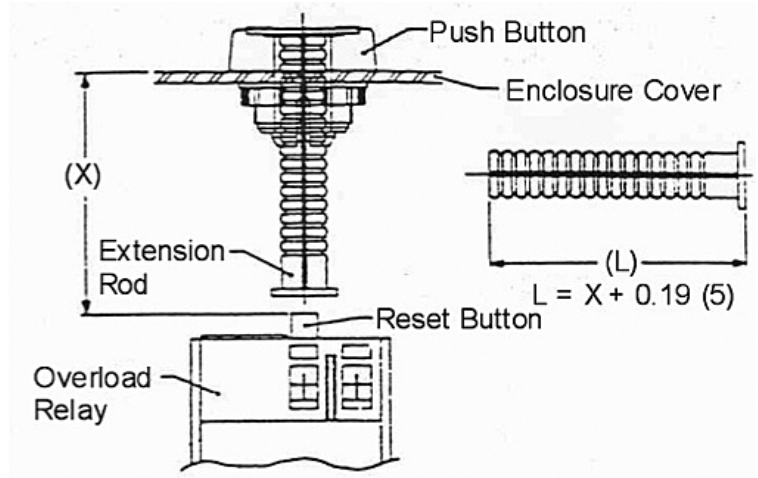

Figure 6. Reset Button installation (Siemens)

Remove the knockout in the cover or door and measure the dimension "X". Add 0.19 inches/5 mm to length "X". Cut or break off the extension rod to the next longer notch; dimension "L".

Install the reset button. Make sure that the reset extension rod does not unintentionally press the reset button with the cover/door closed causing the overload relay to be in a continuous automatic mode and does reset the overload relay when intentionally pressing the button from the front of the enclosure.

Power Supplies

The power supply can be wired separately from the equipment, or a single-phase voltage can be picked up on the magnetic starter so that the power can be controlled with the collection System. Make sure that the three-phase voltage matches the input voltage requirement on the power supply. See Figure 7 and follow the instructions below:

1. Install the power supply securely. Keep free of dirt, oil and water and keep away from excessive heat.
2. If the power supply is not grounded through the line cord, connect a 16 GA copper wire between the ground stud and cold water pipe or a grounded machine frame. Clean the grounding surface of paint, dirt, etc. (DO NOT connect to gas or hot water pipe.)
3. Remove dust cap and insert connector until it engages to the high voltage connector spring. Tighten the screw cap into the high voltage terminal.

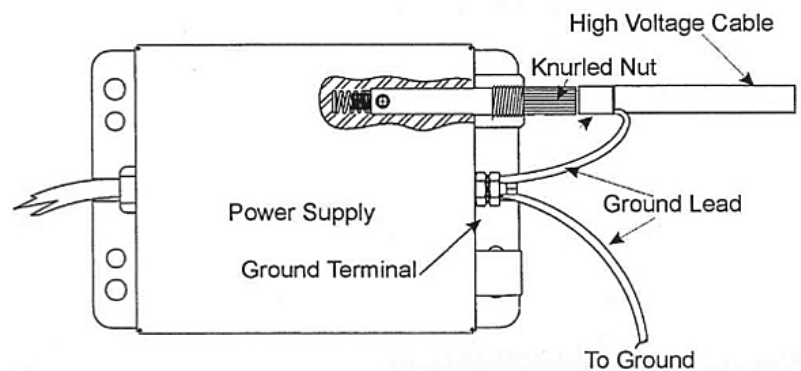

Figure 7. Power Supply

4. Connect the line cord to the electrical supply per nameplate specifications (120V units are supplied with a 3-wire cord and a male plug; 230V units are supplied with a 3-wire cord with a stripped, tinned lead).
5. For added safety and extended life for those units without an integral power switch, input voltage to the power supply should be shut off when not in use. If possible, connect input voltage to the power supply through the machine “ON/OFF” and/or “RUN” circuit.

Static Bars

Before the static bars can be connected to the power supply, the spring loaded cable connector kit must be installed on the cable for the static bar. See Figure 8 for installation of the connector kit to the power cable:

1. Cut cable off at desired length, then slide knurled plug M (knurled end first) over cable.

NOTE: MEASURE CAREFULLY, ACCURACY IS IMPORTANT.

2. Strip ½” insulation off end of cable.
3. Straighten copper conductor wires. DO NOT TWIST.
4. Slide high voltage connector N over conductor until it butts against cable insulation. Be sure all strands of the conductor are inserted into the connector.
5. Slide connector body P over high voltage connector until hole in connector body lines up with set screw hole in the connector.
6. Insert set screw Q in connector through the hole in the connector body and tighten.
7. After tightening, if set screw is not flush with or slightly below surface of connector body P, disassemble and remove additional strands of wire from the conductor to allow the set screw to be at least flush with the connector body P.
8. Pull firmly to be sure voltage connector N is tight on conductor.
9. Turn contact spring R – end with close turns, clockwise, by hand, onto high voltage connector N until spring butts against connector body.
10. If an additional contact is needed on the power supply, remove a plug or cap from one of the other holes in the plastic receptacle. To remove plug or cap, jab a screwdriver with an insulated handle through center and pry off. If plug or cap has a screw slot, turn counterclockwise to remove.
11. Insert the connector into the hole and tighten the knurled plug. FINGER TIGHT ONLY.

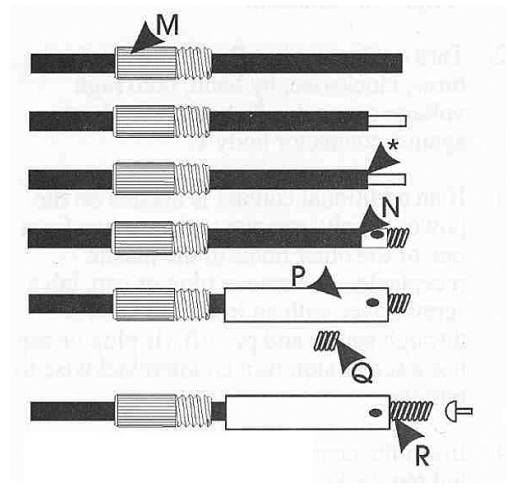

Figure 8. Spring Loaded Connector Installation

Prior To Start-Up

To avoid damage to the press, please use the checklist below before starting up the Ion-O-Vac web and sheet cleaner:

1. **Check Clearances:** Inch the press and check for clearance to the vacuum heads. For a sheet-fed press, make sure that the gripper bars do not hit the vacuum head assembly. For Ion-O-Vacs with a manual or pneumatic retraction system, make sure that the vacuum heads does not interfere with normal press operation both in retracted or normal position.
2. **Check Seams:** To avoid vacuum loss, check all the seams and make sure that they are sealed properly.
3. **Check Voltages:** Double check that all power input corresponds to the nameplates of the collection system, power supplies, drive motors, speed controls and magnetic starter. Make sure that the overload relay is set at the appropriate amperage rating.
4. **Check Dampener Settings:** To avoid damage to the collection system, double check all ducting dampeners to make sure they are open.

6. MAINTENANCE

Although the Ion-O-Vac is virtually maintenance free, a system of preventive maintenance should be set up to insure maximum efficiency and service life paying particular attention to the following points:

Vacuum Heads

1. Check the orifice and clean out as necessary. A small stiff brush or a blast of high pressure air should be sufficient.
2. Remove the flex hose connection from the vacuum head assembly and check for any sheets or material that might have been “sucked” inside the vacuum head.
3. The brushes should be cleaned or replaced regularly. The length of time between cleaning and replacement will be dependent primarily on the nature of the material being cleaned. Brush bristles should not be permitted to become stiff with ink or coatings or become excessively dirty.
4. Check the brush setting in relation to the material being cleaned, refer to Section 2 Brush Settings.
5. Check all mounting bolts and tighten as necessary.

Static Bars

For maximum efficiency, it is essential that the ionizing points located on the inner bar be kept clean. If metal filings or material fragments fall into the static bars, they can short circuit that section of the bar and make it inoperative until the particles are removed. Periodic use of a soft brush or compressed air will prevent the points from accumulating hardened balls of lint, grease and other foreign matter that reduce their sharpness and decrease efficiency.

1. Turn off line power to the power supply before cleaning, removing static bars from the vacuum heads or machine or before breaking any ground connections.
2. Remove loose particles with compressed air.
3. To remove built-up deposits, press a soft pencil eraser down on the emitter point. Twist the pencil slightly and remove.
4. If particles cannot be dislodged with air or soft pencil erasers, remove the bar, turn the bar face down and tap it. Mount the bar back in position and tighten.
5. Resistant coatings may be removed with Isopropyl Alcohol (without additives) applied with a clean cloth.
 - Do not pour Isopropyl Alcohol on the bar or soak the bar or any of its components in the alcohol.
 - Do not use any other commercial cleaners or solvents, or parts may be damaged. Dry thoroughly.
 - Do not attempt to scrape the points. The points must remain as sharp as possible for optimum operation. If the points become dull or damaged, the bar must be replaced.
 - Let all alcohol evaporate completely before restoring power to the bar.

Flexible Tubing or Ducts

1. Ducting should be checked for blow-outs, punctures or other openings.
2. Check for any restrictions or dirt accumulation inside the ducting.

Collection System

This system incorporates an audible alarm which activates when the filter needs to be cleaned or replaced. Make sure that the bypass air inlet (between the canister and blower) is clean and open.

To clean the filter, blow from inside out with a high pressure air hose. The pre filter may be washed out with mild soap and water.

7. TROUBLESHOOTING

Static Bar Operational Test

Equipment Needed: TensION Voltage Detector (Part # 4050556)



WARNING! Fire Hazard

Remove intrinsically safe equipment from hazardous area or wait until hazardous area clears of all volatile fumes before performing this procedure.



CAUTION: High Voltage - Refer testing to qualified personnel

Hold the TensION at a distance from the ionizing points/emitters. If a high voltage is present, a red indicator in the plastic tip will illuminate.

1. If test produces no indication of voltage, perform static bar cleaning procedure then check affected points for metal fragments. Repeat Steps 1 of the static bar operational test after performing cleaning procedure.
2. If TensION shows no indication of voltage on any points, perform power supply test (see below).
3. If it is determined that the power supply is operative, and more than one static bar is in use, locate the faulty bar.



CAUTION! Electrical Shock Hazard

Power supply must be turned off during disconnection and re-connection of static bar.

1. Disconnect all but one static bar from the high voltage terminal.
2. Use TensION to test several points on the bar. If orange-red glow occurs, the bar is functioning properly. Disconnect that bar and reconnect next bar. Check all bars until faulty bar(s) is located by no glow.

D167RY, D267RY, F167, and F267 Power Unit Operational Test

Equipment needed:

- Multimeter – Fluke Model 70 Series or equivalent
- High Voltage Probe – Fluke Model 80 K or equivalent with minimum 20 KVAC rating



CAUTION: High Voltage

Refer testing to qualified service personnel. Failure to do this can affect a product's operation and can result in personal injury.

1. Verify power supply is off and static bar(s) are disconnected.
2. Set multimeter for AC voltage so that it can read 20 KVAC full scale. Connect high voltage probe to multimeter and connect ground lead on high voltage probe to ground.
3. Connect a short (approximately 4") piece of stiff wire to contact on end of high voltage probe.
4. Insert wire into high voltage connector making contact with screw head inside high voltage connector on power supply.
5. Turn on power supply. Operating voltage should be between 7500 VAC and 8100 VAC. The power supply is not functioning properly if it is not operating between these voltages.



NOTE: Input voltage to power supply must be the same as on power supply label.

6. Turn off power supply.
7. Remove high voltage probe from connector in power supply.

Dust Collector



CAUTION! Electrical Shock Hazard

A qualified electrician must perform all electrical work. Failure to do this can affect a product's operation and can result in personal injury.

If blower motor will not start:

- Proper wire size was not used. Rewire per local and national codes
- Motor is not wired correctly. Rewire, referring to motor wiring diagram located on motor
- Unit is not wired for available voltage. Correct wiring for proper input voltage
- Input circuit down. Check input to motor circuits for voltage on all leads



NOTE: A blower motor is easily overloaded when it is forced to handle too much air. An insufficient air supply causes few, if any, problems. Simco-Ion Dust Collectors are designed to make maximum use of the motor's horsepower but, they are not under powered. Any motor that indicates an amperage draw in excess of 10% of the manufacturer's recommendation on the nameplate is overloaded. Overloading may be caused by one or more of the conditions under "if blower motor will not start."

If blower motor starts, but does not keep running:

- Incorrect starter heater elements are installed. Replace with proper heater elements
- Slide gate or hopper exits are not closed properly. Close gate or exits properly
- Insufficient supply voltage. Check the supply voltage to verify that it meets the motor manufacturer's requirements on the nameplate
- Insufficient air flow
- Fan rotating backwards. Change the fan rotation (for three phase only):
 - Disconnect dust collector from electrical outlet
 - Look at the rotation sticker on the fan housing for proper rotation direction
 - Change the motor rotation by interchanging any two supply leads (three phase only). On single phase motors, the internal wiring will have to be changed. Reference motor wiring diagram
 - Reconnect dust collector to electrical outlet

Ducting Collapsed or Plugged

- Remove and replace collapsed ducting
- Remove and clean out debris that is blocking ducting

Fan Exhaust is Restricted

- Remove the debris that is blocking the fan exhaust area
- Remove all loose material stored on top of the collector

Filter is Plugged with Fibrous Material

- Disconnect dust collector from electrical outlet
- Empty the filter canister
- Reconnect dust collector to electrical outlet

8. WARRANTY

This product has been carefully tested at the factory and is warranted to be free from any defects in materials or workmanship. Simco-Ion will, under this warranty, repair or replace any equipment that proves, upon our examination, to have become defective within one year from the date of purchase.

The equipment being returned under warranty should be shipped by the purchaser to Simco-Ion, 2257 North Penn Road, Hatfield PA 19440, transportation prepaid and insured for its replacement cost. Prior to returning any goods for any reason, contact Simco-Ion Customer Service at (215) 822-6401 for a Return Authorization Number. This number must accompany all returned items.

This warranty does not apply when the equipment has been tampered with, misused, improperly installed, altered, has received damage through abuse, carelessness, accident, connected to improper line voltage, or has been serviced anyone other than an authorized factory representative.

The warranty does not apply when Simco-Ion parts and equipment have been energized by other than the appropriate Simco-Ion power supply or generator, or when a Simco-Ion power supply or generator has been used to energize other than Simco-Ion parts and equipment. Simco-Ion makes no warranty, expressed or implied, nor accepts any obligation, liabilities, or responsibility in connection with the use of this product other than the repair or replacement of parts stated herein.

Information in this publication supersedes that in all previous published material. Specifications are subject to change without notice.

9. DIMENSIONAL DRAWINGS (FOR REFERENCE ONLY)

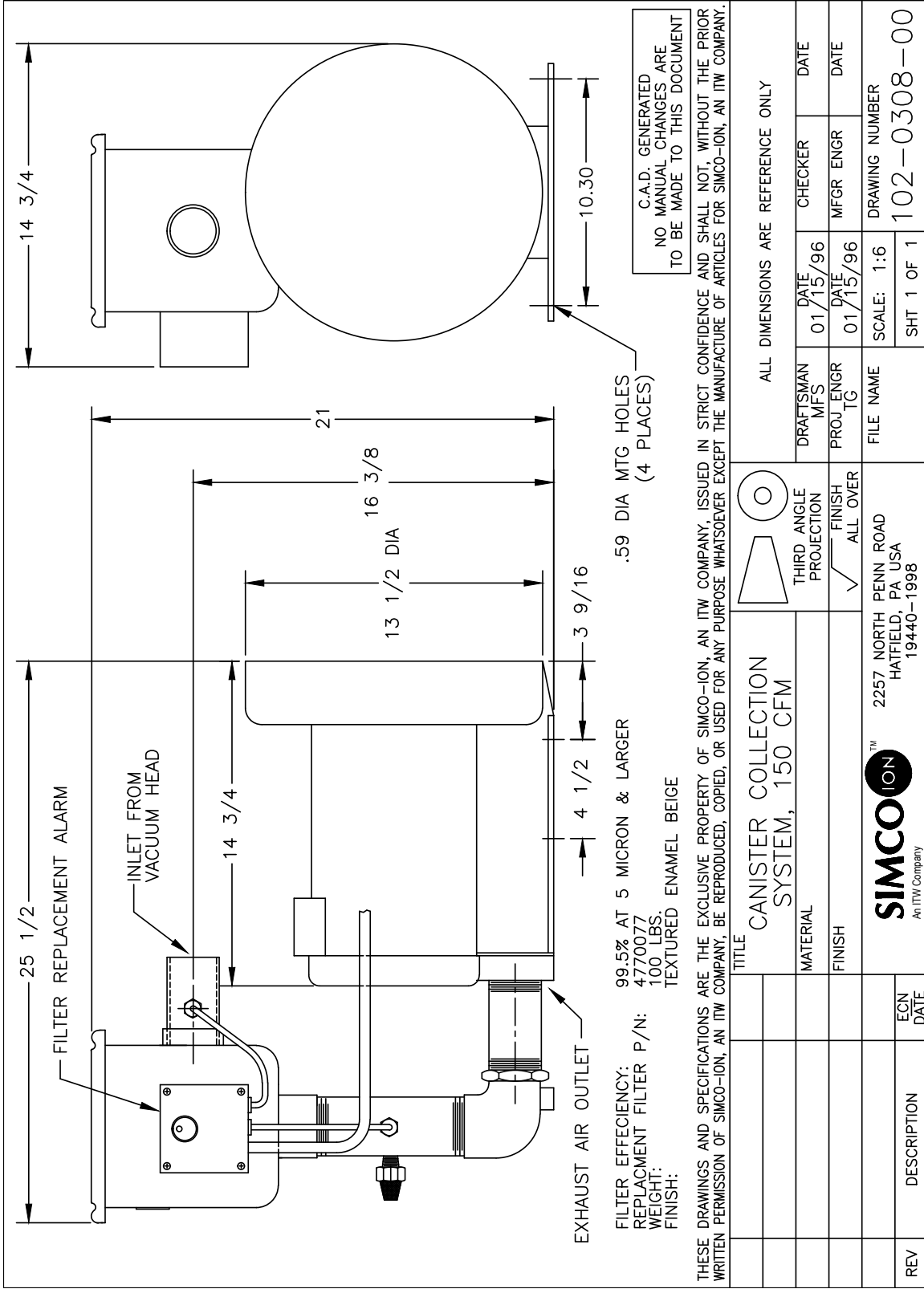

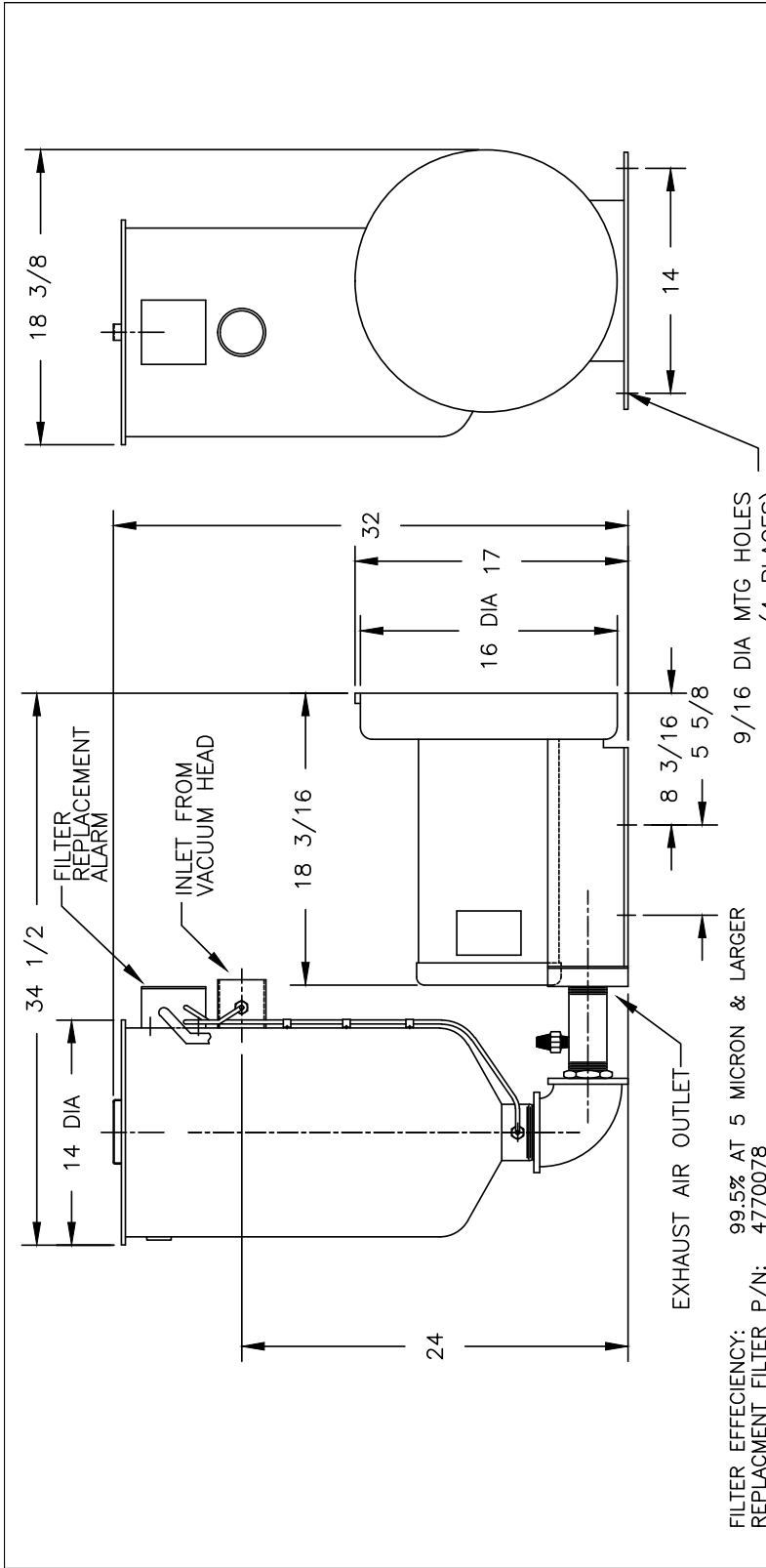

C.A.D. GENERATED
NO MANUAL CHANGES ARE
TO BE MADE TO THIS DOCUMENT

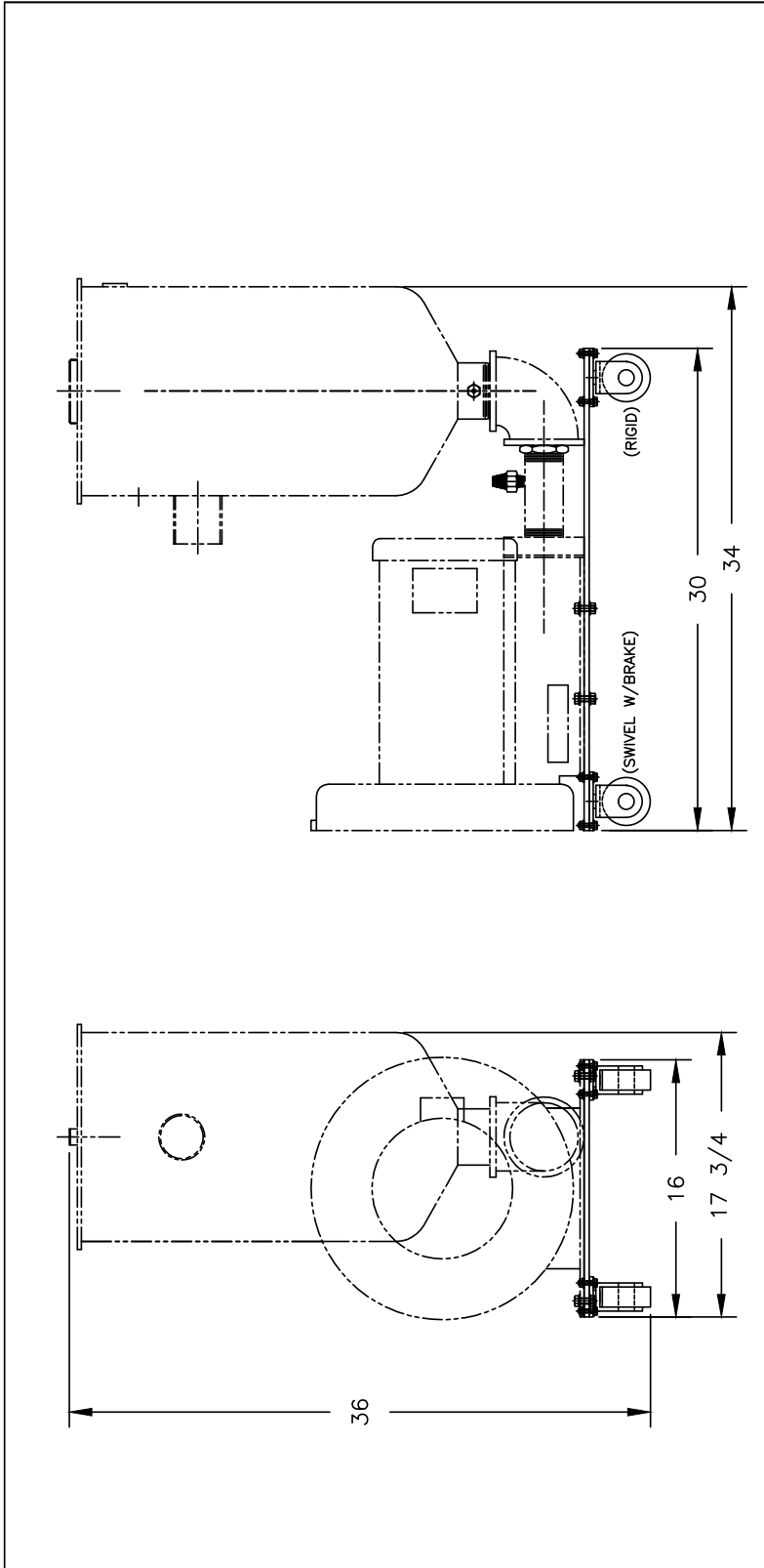

THESE DRAWINGS AND SPECIFICATIONS ARE THE EXCLUSIVE PROPERTY OF SIMCO-ION, AN ITW COMPANY, ISSUED IN STRICT CONFIDENCE AND SHALL NOT, WITHOUT THE PRIOR WRITTEN PERMISSION OF SIMCO-ION, AN ITW COMPANY, BE REPRODUCED, COPIED, OR USED FOR ANY PURPOSE WHATSOEVER EXCEPT THE MANUFACTURE OF ARTICLES FOR SIMCO-ION, AN ITW COMPANY.

REV	DESCRIPTION	ECN DATE	 THIRD ANGLE PROJECTION		ALL DIMENSIONS ARE REFERENCE ONLY	
			TITLE	CANISTER COLLECTION SYSTEM, 300 CFM	DRAFTSMAN MFS	DATE 01/15/96
			MATERIAL		PROJ_ENGR TG	DATE 01/15/96
			FINISH	125 FINISH ALL OVER	FILE NAME	DRAWING NUMBER
				2257 NORTH PENN ROAD HATFIELD, PA USA 19440-1998	SCALE: 1:10	102-0309-00
				 SIMCOION™ An ITW Company	SHT 1 OF 1	



C.A.D. GENERATED
NO MANUAL CHANGES ARE
TO BE MADE TO THIS DOCUMENT

THESE DRAWINGS AND SPECIFICATIONS ARE THE EXCLUSIVE PROPERTY OF SIMCO-ION, AN ITW COMPANY, ISSUED IN STRICT CONFIDENCE AND SHALL NOT, WITHOUT THE PRIOR WRITTEN PERMISSION OF SIMCO-ION, AN ITW COMPANY, BE REPRODUCED, COPIED, OR USED FOR ANY PURPOSE WHATSOEVER EXCEPT THE MANUFACTURE OF ARTICLES FOR SIMCO-ION, AN ITW COMPANY.

REV	DESCRIPTION	ECN DATE	 2257 NORTH PENN ROAD HATFIELD, PA USA 19440-1998 An ITW Company		TITLE IOV 300 CFM CAN ROLLER PLATE ASSY	THIRD ANGLE PROJECTION 	DRAFTSMAN MFS	DATE 01/19/05	CHECKER DATE
					FINISH N/A	PROJ ENGR SRM	DATE 01/19/05	MFGR ENGR DATE	FILE NAME SCALE: 1:10
									DRAWING NUMBER 102-0321-00
									SHT 1 OF 1

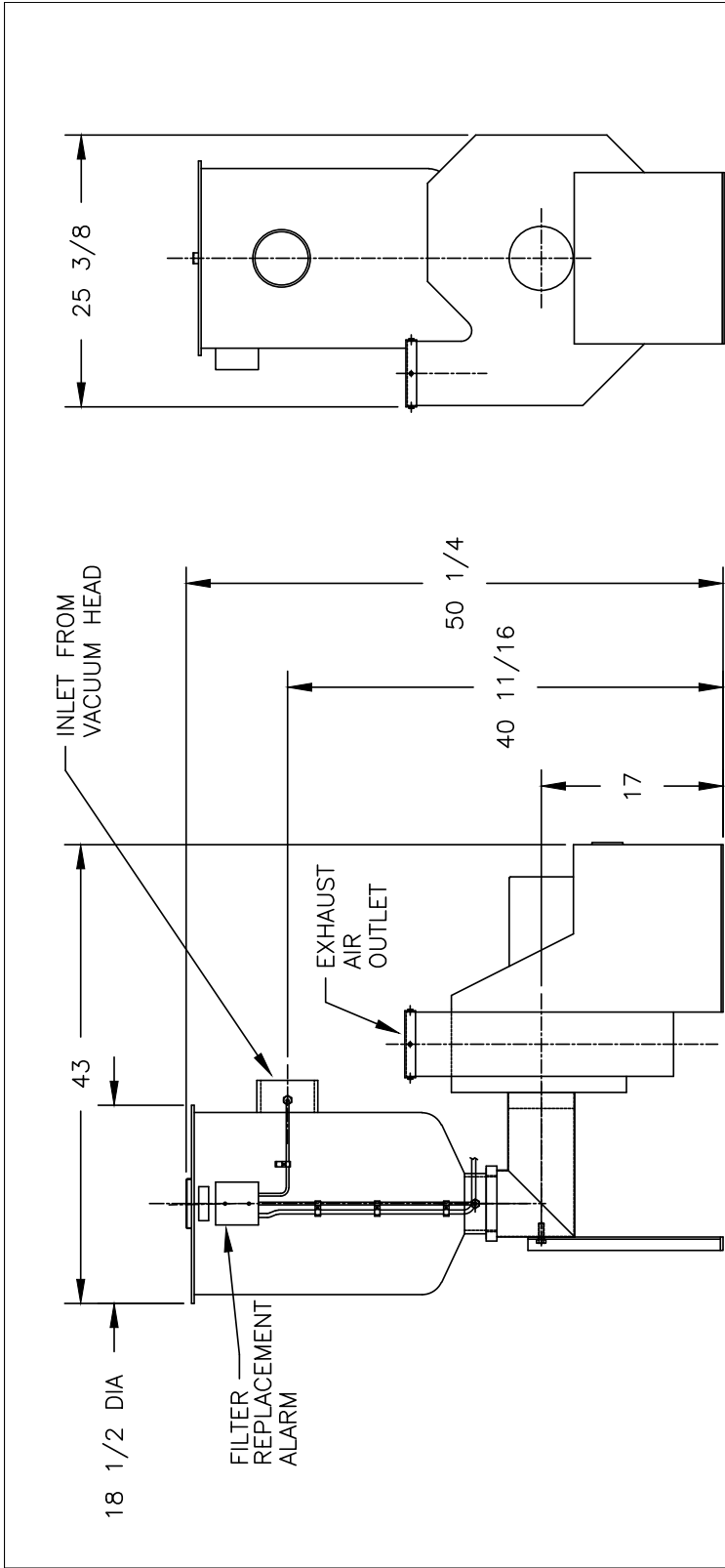

FILTER EFFECIENCY: 99% AT 5 MICRON & LARGER
 REPLACMENT FILTER P/N: 4770089
 WEIGHT: 370 LBS.
 FINISH: TEXTURED ENAMEL BEIGE

C.A.D. GENERATED
 NO MANUAL CHANGES ARE
 TO BE MADE TO THIS DOCUMENT

THESE DRAWINGS AND SPECIFICATIONS ARE THE EXCLUSIVE PROPERTY OF SIMCO-ION, AN ITW COMPANY, ISSUED IN STRICT CONFIDENCE AND SHALL NOT, WITHOUT THE PRIOR WRITTEN PERMISSION OF SIMCO-ION, AN ITW COMPANY, BE REPRODUCED, COPIED, OR USED FOR ANY PURPOSE WHATSOEVER EXCEPT THE MANUFACTURE OF ARTICLES FOR SIMCO-ION, AN ITW COMPANY.

REV	DESCRIPTION	ECN DATE	 THIRD ANGLE PROJECTION		ALL DIMENSIONS ARE REFERENCE ONLY	
			TITLE	DRAFTSMAN MFS	DATE 01/17/96	CHECKER
			800 CFM WITHOUT SILENCER	PROJ ENGR TG	DATE 01/17/96	MFR ENGR
			MATERIAL	FILE NAME	SCALE: 1:15	DRAWING NUMBER
			FINISH	2257 NORTH PENN ROAD HATFIELD, PA USA 19440-1998	SHT 1 OF 1	102-0310-00

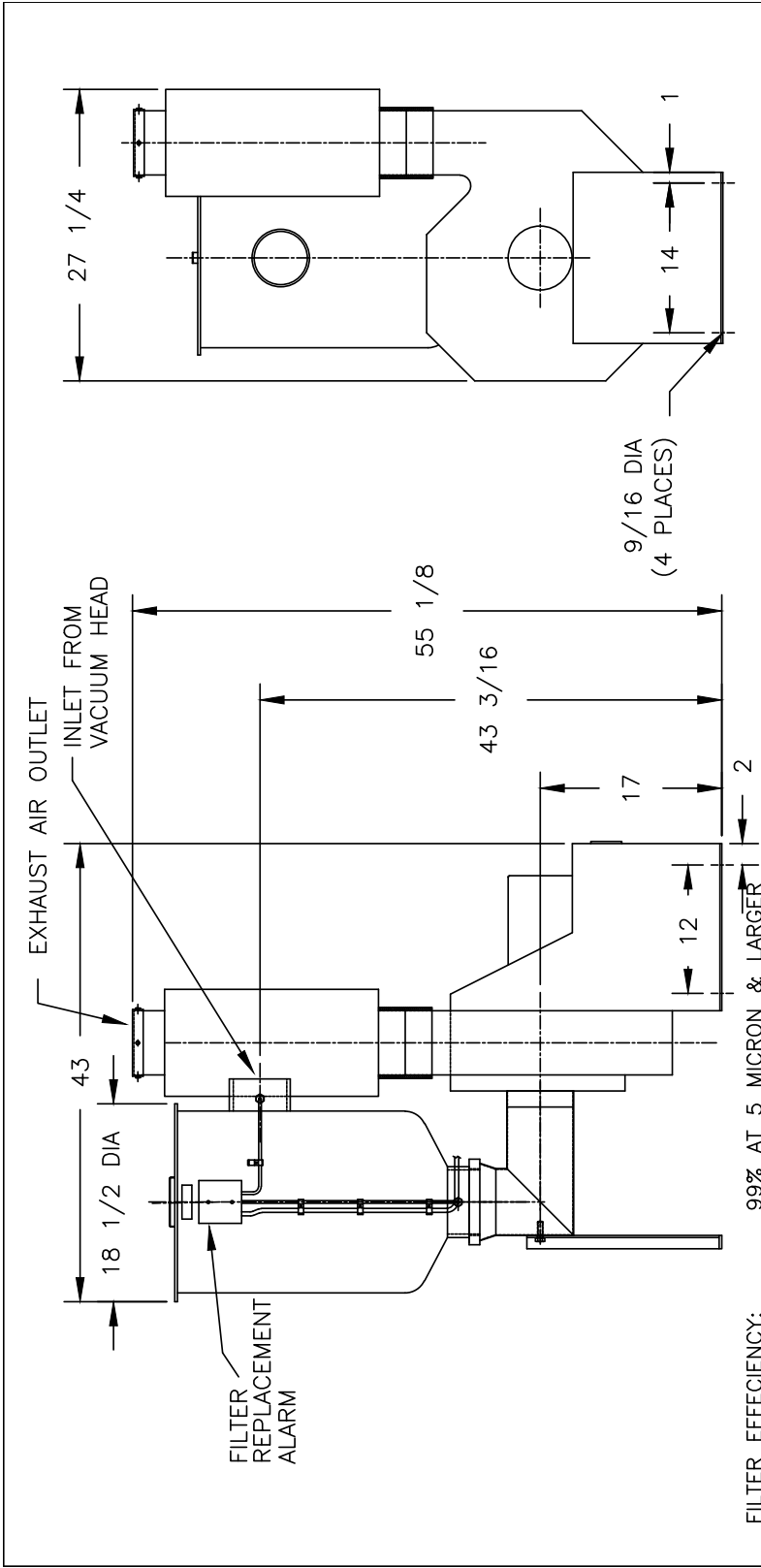

C.A.D. GENERATED
NO MANUAL CHANGES ARE
TO BE MADE TO THIS DOCUMENT

FILTER EFFECIENCY: 99% AT 5 MICRON & LARGER
REPLACEMENT FILTER P/N: 4770090
WEIGHT: 385 LBS.
FINISH: TEXTURED ENAMEL BEIGE

THESE DRAWINGS AND SPECIFICATIONS ARE THE EXCLUSIVE PROPERTY OF SIMCO-ION, AN ITW COMPANY, ISSUED IN STRICT CONFIDENCE AND SHALL NOT, WITHOUT THE PRIOR WRITTEN PERMISSION OF SIMCO-ION, AN ITW COMPANY, BE REPRODUCED, COPIED, OR USED FOR ANY PURPOSE WHATSOEVER EXCEPT THE MANUFACTURE OF ARTICLES FOR SIMCO-ION, AN ITW COMPANY.

REV	DESCRIPTION	ECN DATE	 THIRD ANGLE PROJECTION	 125 FINISH ALL OVER	2257 NORTH PENN ROAD HATFIELD, PA USA 19440-1998	SIMCO-ION An ITW Company	CANISTER COLL SYS 1100 CFM WITH SILENCER	DRAFTSMAN MFS DATE 02/14/96	CHECKER DATE	ALL DIMENSIONS ARE REFERENCE ONLY

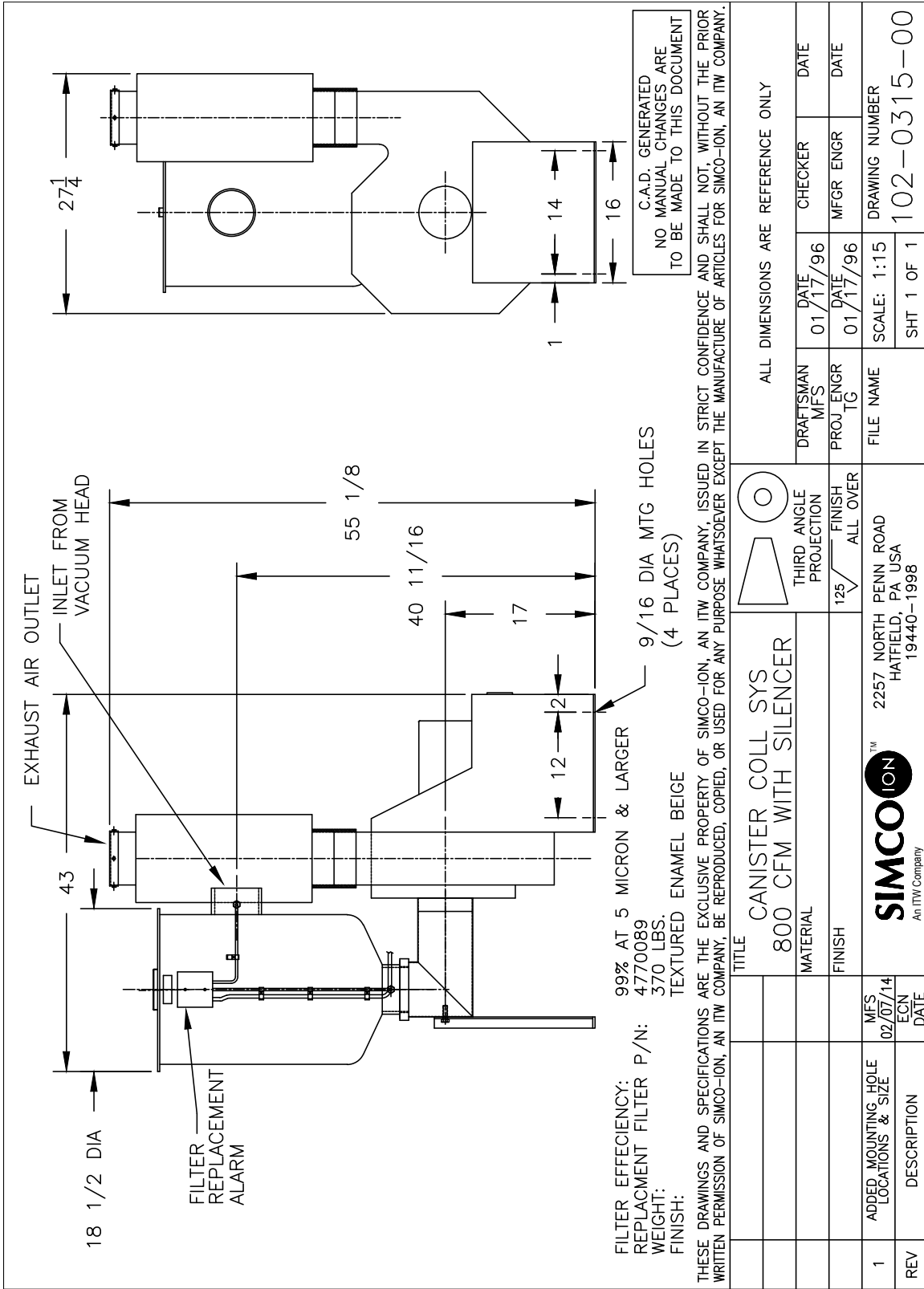

FILTER EFFECIENCY: 99% AT 5 MICRON & LARGER
 REPLACMENT FILTER P/N: 4770089
 WEIGHT: 370 LBS.
 FINISH: TEXTURED ENAMEL BEIGE

THESE DRAWINGS AND SPECIFICATIONS ARE THE EXCLUSIVE PROPERTY OF SIMCO-ION, AN ITW COMPANY, ISSUED IN STRICT CONFIDENCE AND SHALL NOT, WITHOUT THE PRIOR WRITTEN PERMISSION OF SIMCO-ION, AN ITW COMPANY, BE REPRODUCED, COPIED, OR USED FOR ANY PURPOSE WHATSOEVER EXCEPT THE MANUFACTURE OF ARTICLES FOR SIMCO-ION, AN ITW COMPANY.

TITLE		THIRD ANGLE PROJECTION		ALL DIMENSIONS ARE REFERENCE ONLY	
CANISTER COLL SYS		125 FINISH ALL OVER		DRAFTSMAN	DATE
800 CFM WITH SILENCER		125 FINISH ALL OVER		MFS	01/17/96
MATERIAL		125 FINISH ALL OVER		PROJ ENGR	DATE
FINISH		125 FINISH ALL OVER		TG	01/17/96
ADDED MOUNTING HOLE LOCATIONS & SIZE		MFS		FILE NAME	SCALE: 1:15
1		02/07/14		102-0315-00	
DESCRIPTION		ECN		SHT 1 OF 1	
REV		DATE		DRAWING NUMBER	

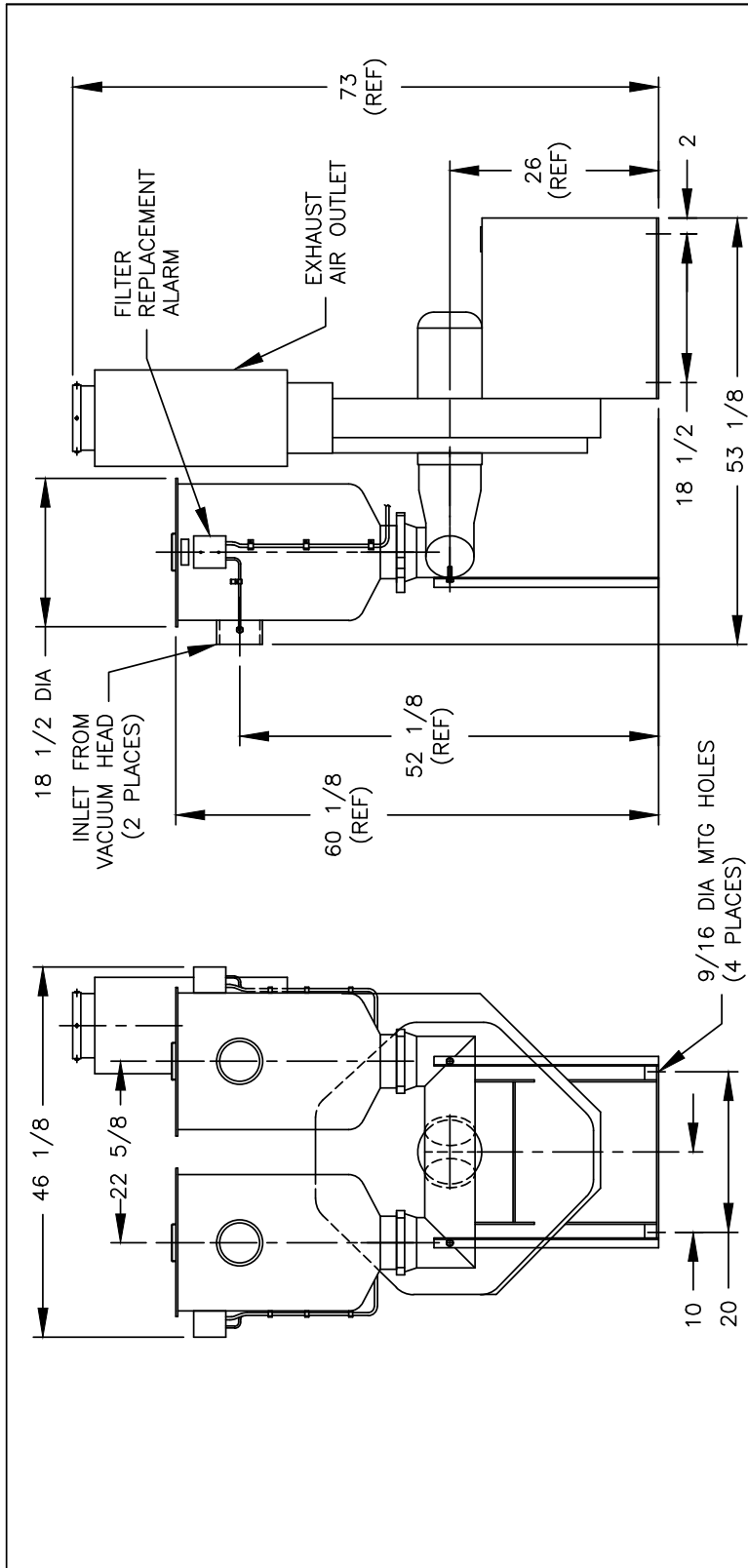

FILTER EFFICIENCY: 99.5% AT 5 MICRON & LARGER
 REPLACEMENT FILTER P/N: 4770090
 WEIGHT: 525 LBS.
 FINISH: TEXTURED ENAMEL BEIGE

C.A.D. GENERATED
 NO MANUAL CHANGES ARE
 TO BE MADE TO THIS DOCUMENT

THESE DRAWINGS AND SPECIFICATIONS ARE THE EXCLUSIVE PROPERTY OF SIMCO-ION, AN ITW COMPANY, ISSUED IN STRICT CONFIDENCE AND SHALL NOT, WITHOUT THE PRIOR WRITTEN PERMISSION OF SIMCO-ION, AN ITW COMPANY, BE REPRODUCED, COPIED, OR USED FOR ANY PURPOSE WHATSOEVER EXCEPT THE MANUFACTURE OF ARTICLES FOR SIMCO-ION, AN ITW COMPANY.

REV	DESCRIPTION	ECN DATE	TITLE		THIRD ANGLE PROJECTION		ALL DIMENSIONS ARE REFERENCE ONLY	
			CANISTER COLL SYS		125 FINISH ALL OVER		DRAFTSMAN	DATE
			2200 CFM, DBL CAN		ALL OVER		JSB	01/21/97
							PROJ ENGR	DATE
							MFS	02/17/97
							FILE NAME	SCALE: 1:20
							DRAWING NUMBER	
							102-0317-00	



2257 NORTH PENN ROAD
 HATFIELD, PA USA
 19440-1998

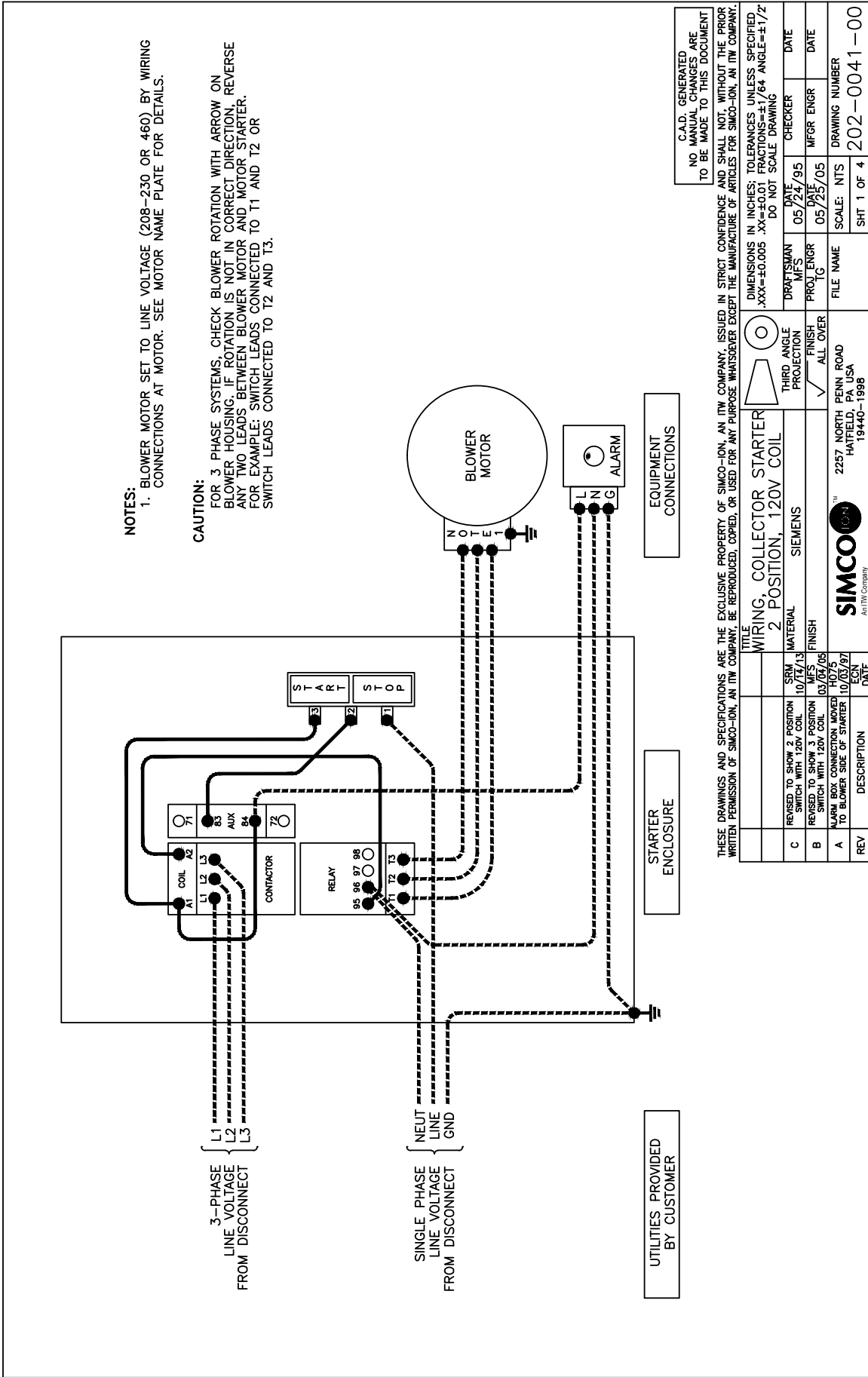

NOTES:

1. BLOWER MOTOR SET TO LINE VOLTAGE (208-230 OR 460) BY WIRING CONNECTIONS AT MOTOR. SEE MOTOR NAME PLATE FOR DETAILS.

CAUTION:

FOR 3 PHASE SYSTEMS, CHECK BLOWER ROTATION WITH ARROW ON BLOWER HOUSING. IF ROTATION IS NOT IN CORRECT DIRECTION, REVERSE ANY TWO LEADS BETWEEN BLOWER MOTOR AND MOTOR STARTER. FOR EXAMPLE: SWITCH LEADS CONNECTED TO T1 AND T2 OR SWITCH LEADS CONNECTED TO T2 AND T3.

C.A.D. GENERATED
NO MANUAL CHANGES ARE
TO BE MADE TO THIS DOCUMENT

THESE DRAWINGS AND SPECIFICATIONS ARE THE EXCLUSIVE PROPERTY OF SIMCO-ION, AN ITW COMPANY, ISSUED IN STRICT CONFIDENCE AND SHALL NOT, WITHOUT THE PRIOR WRITTEN PERMISSION OF SIMCO-ION, AN ITW COMPANY, BE REPRODUCED, COPIED, OR USED FOR ANY PURPOSE WHATSOEVER EXCEPT THE MANUFACTURE OF ARTICLES FOR SIMCO-ION, AN ITW COMPANY.

DIMENSIONS IN INCHES; TOLERANCES UNLESS SPECIFIED:
.XXY=±0.01 FRACTIONS=±1/64 ANGLE=±1/2
DO NOT SCALE DRAWING

DRAFTSMAN MFS	DATE 05/24/95	CHECKER	DATE
PROJ ENGR TG	DATE 05/25/05	MFR ENGR	DATE

TITLE WIRING, COLLECTOR STARTER 2 POSITION, 120V COIL	THIRD ANGLE PROJECTION	FINISH ALL OVER
MATERIAL SIEMENS		

REV	DESCRIPTION	DATE	ECN
C	REVISED TO SHOW 2 POSITION STARTER WITH 120V COIL SWITCH	10/15/13	
B	REVISED TO SHOW 3 POSITION SWITCH WITH 120V COIL	03/03/05	
A	ALARM BOX CONNECTION MOVED TO BLOWER SIDE OF STARTER	10/03/97	

2257 NORTH PENN ROAD
HAITFIELD, PA USA
19440-1998



202-0041-00
SHT 1 OF 4

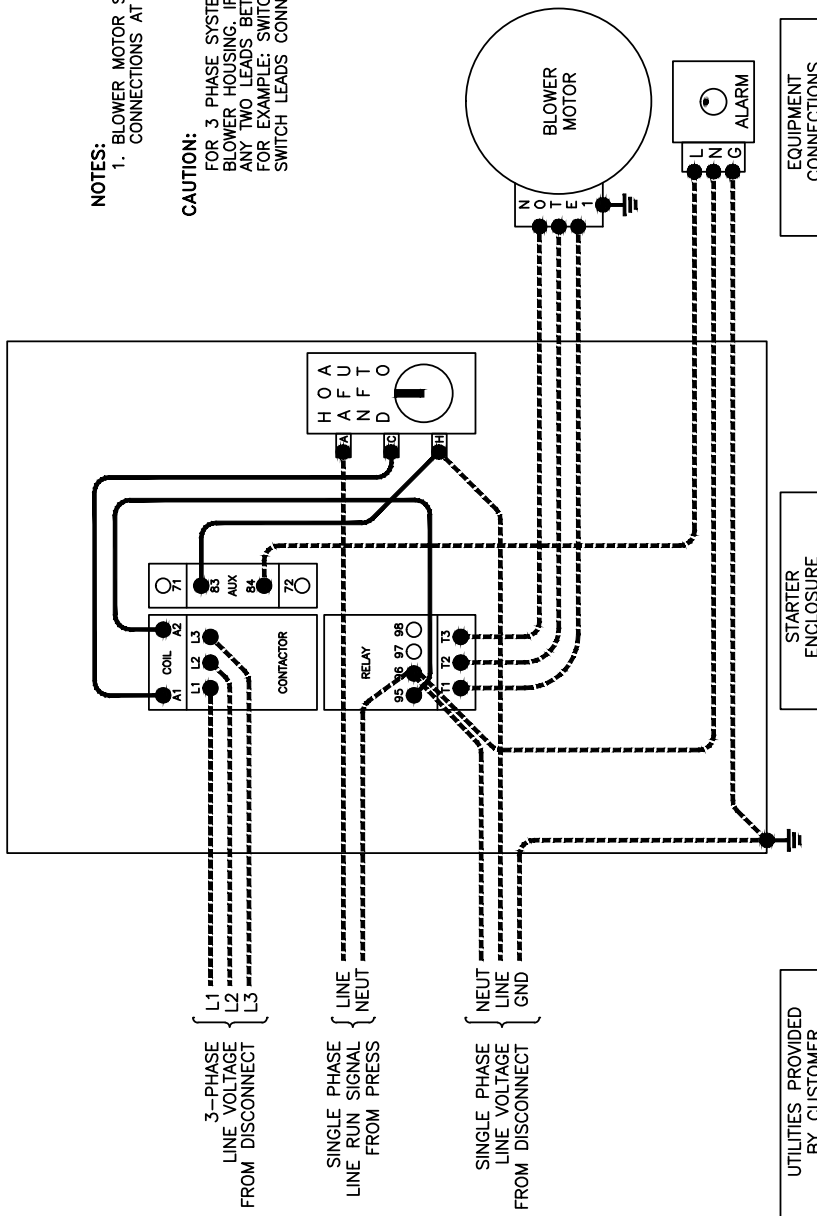

NOTES:
 1. BLOWER MOTOR SET TO LINE VOLTAGE (208-230 OR 460) BY WIRING CONNECTIONS AT MOTOR. SEE MOTOR NAME PLATE FOR DETAILS.

CAUTION:
 FOR 3 PHASE SYSTEMS, CHECK BLOWER ROTATION WITH ARROW ON BLOWER HOUSING. IF ROTATION IS NOT IN CORRECT DIRECTION, REVERSE ANY TWO LEADS BETWEEN BLOWER MOTOR AND MOTOR STARTER. FOR EXAMPLE: SWITCH LEADS CONNECTED TO T1 AND T2 OR SWITCH LEADS CONNECTED TO T2 AND T3.

UTILITIES PROVIDED BY CUSTOMER

STARTER ENCLOSURE

EQUIPMENT CONNECTIONS

C.A.D. GENERATED
 NO MANUAL CHANGES ARE TO BE MADE TO THIS DOCUMENT

THESE DRAWINGS AND SPECIFICATIONS ARE THE EXCLUSIVE PROPERTY OF SIMCO-ION, AN ITW COMPANY. ISSUED IN STRICT CONFIDENCE AND SHALL NOT, WITHOUT THE PRIOR WRITTEN PERMISSION OF SIMCO-ION, AN ITW COMPANY, BE REPRODUCED, COPIED, OR USED FOR ANY PURPOSE WHATSOEVER EXCEPT THE MANUFACTURE OF ARTICLES FOR SIMCO-ION, AN ITW COMPANY.

SEE SHEET 1 FOR	TITLE	DATE	DRAFTSMAN	CHECKER
REVISION HISTORY	WIRING, COLLECTOR STARTER 3 POSITION, 120V COIL	05/24/95	MFS	
REVISED TO SHOW 3 POSITION SWITCH WITH 120V COIL	THIRD ANGLE PROJECTION	DATE	PROJ ENGR	DATE
	FINISH ALL OVER	10/14/15	TG	05/25/05
DESCRIPTION	2257 NORTH PENN ROAD HAIFIELD, PA USA 19440-1998	SCALE: NTS	FILE NAME	DRAWING NUMBER
				202-0041-00
				SHT 2 OF 4

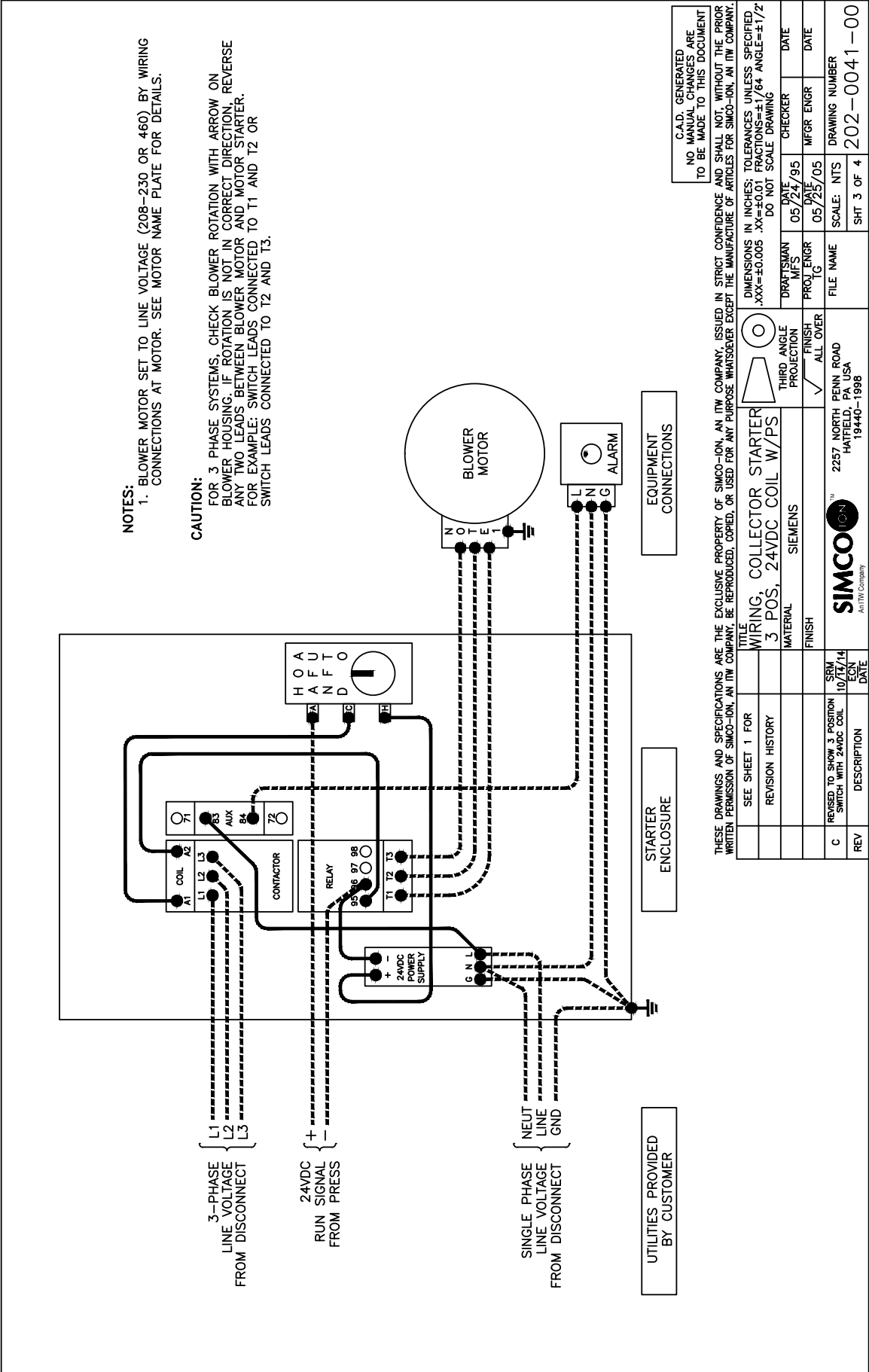

NOTES:
 1. BLOWER MOTOR SET TO LINE VOLTAGE (208-230 OR 460) BY WIRING CONNECTIONS AT MOTOR. SEE MOTOR NAME PLATE FOR DETAILS.

CAUTION:
 FOR 3 PHASE SYSTEMS, CHECK BLOWER ROTATION WITH ARROW ON BLOWER HOUSING. IF ROTATION IS NOT IN CORRECT DIRECTION, REVERSE ANY TWO LEADS BETWEEN BLOWER MOTOR AND MOTOR STARTER. FOR EXAMPLE: SWITCH LEADS CONNECTED TO T1 AND T2 OR SWITCH LEADS CONNECTED TO T2 AND T3.

C.A.D. GENERATED
 NO MANUAL CHANGES ARE
 TO BE MADE TO THIS DOCUMENT

THESE DRAWINGS AND SPECIFICATIONS ARE THE EXCLUSIVE PROPERTY OF SIMCO-ION, AN ITW COMPANY, ISSUED IN STRICT CONFIDENCE AND SHALL NOT, WITHOUT THE PRIOR WRITTEN PERMISSION OF SIMCO-ION, AN ITW COMPANY, BE REPRODUCED, COPIED, OR USED FOR ANY PURPOSE WHATSOEVER EXCEPT THE MANUFACTURE OF ARTICLES FOR SIMCO-ION, AN ITW COMPANY.

SEE SHEET 1 FOR		TITLE	WIRING, COLLECTOR STARTER	THIRD ANGLE PROJECTION	DRAFTSMAN	DATE	CHECKER	DATE
REVISION HISTORY		MATERIAL	3 POS, 24VDC COIL W/P/S	FINISH ALL OVER	M/PS	05/24/95		
					PROJ ENGR	05/28/05		
		FINISH	SIEMENS		TG			
		SRM TO SHOW 3 POSITION SWITCH WITH 24VDC COIL						
		10/13/14						
REV	C	DESCRIPTION			FILE NAME	SCALE: NTS	DRAWING NUMBER	
					2257 NORTH PENN ROAD HATFIELD, PA USA 19440-1998		202-0041-00	
								SHT 3 OF 4

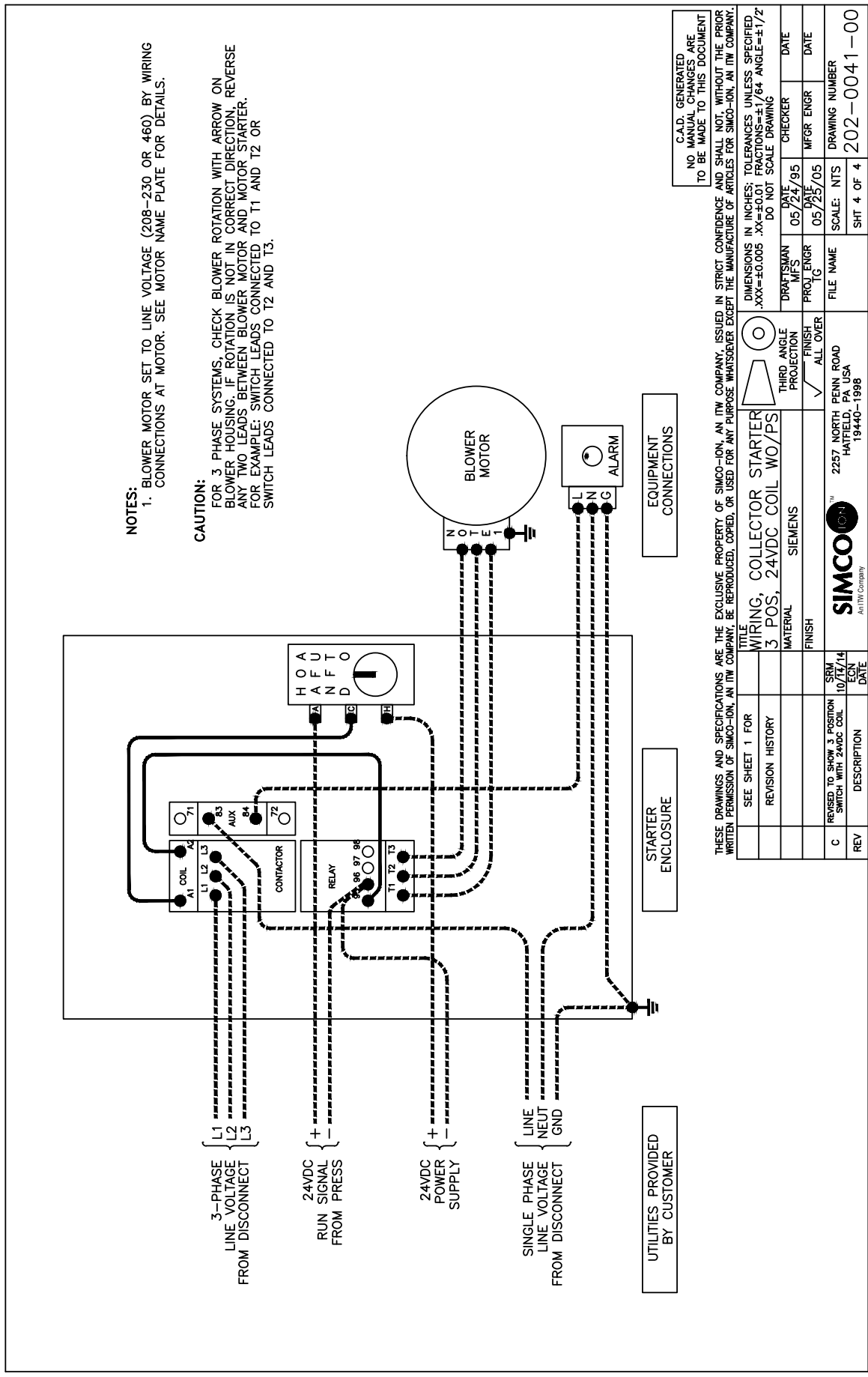

NOTES:
 1. BLOWER MOTOR SET TO LINE VOLTAGE (208-230 OR 460) BY WIRING CONNECTIONS AT MOTOR. SEE MOTOR NAME PLATE FOR DETAILS.

CAUTION:
 FOR 3 PHASE SYSTEMS, CHECK BLOWER ROTATION WITH ARROW ON BLOWER HOUSING. IF ROTATION IS NOT IN CORRECT DIRECTION, REVERSE ANY TWO LEADS BETWEEN BLOWER MOTOR AND MOTOR STARTER. FOR EXAMPLE: SWITCH LEADS CONNECTED TO T1 AND T2 OR SWITCH LEADS CONNECTED TO T2 AND T3.

C.A.D. GENERATED
 NO MANUAL CHANGES ARE
 TO BE MADE TO THIS DOCUMENT

THESE DRAWINGS AND SPECIFICATIONS ARE THE EXCLUSIVE PROPERTY OF SIMCO-ION, AN ITW COMPANY. ISSUED IN STRICT CONFIDENCE AND SHALL NOT, WITHOUT THE PRIOR WRITTEN PERMISSION OF SIMCO-ION, AN ITW COMPANY, BE REPRODUCED, COPIED, OR USED FOR ANY PURPOSE WHATSOEVER EXCEPT THE MANUFACTURE OF ARTICLES FOR SIMCO-ION, AN ITW COMPANY.

SEE SHEET 1 FOR									
REVISION HISTORY									
REV	DESCRIPTION	DATE	BY	ECN	DATE				
C	REFER TO SHOW 3 POSITION SWITCH WITH 24VDC COIL	10/14/14	SRM						

TITLE	WIRING, COLLECTOR STARTER	THIRD ANGLE PROJECTION	DRAFTSMAN	DATE	CHECKER	DATE
MATERIAL	3 POS, 24VDC COIL WO/PS	SIEMENS	MFS	05/24/95		
FINISH	ALL OVER	FINISH	PROLENGR	05/23/05	MFR ENGR	DATE
FILE NAME	2257 NORTH PENN ROAD HAITFIELD, PA USA 19440-1998	FILE NAME				
DRAWING NUMBER	202-0041-00	SCALE:	NTS			
SHT	4 OF 4					

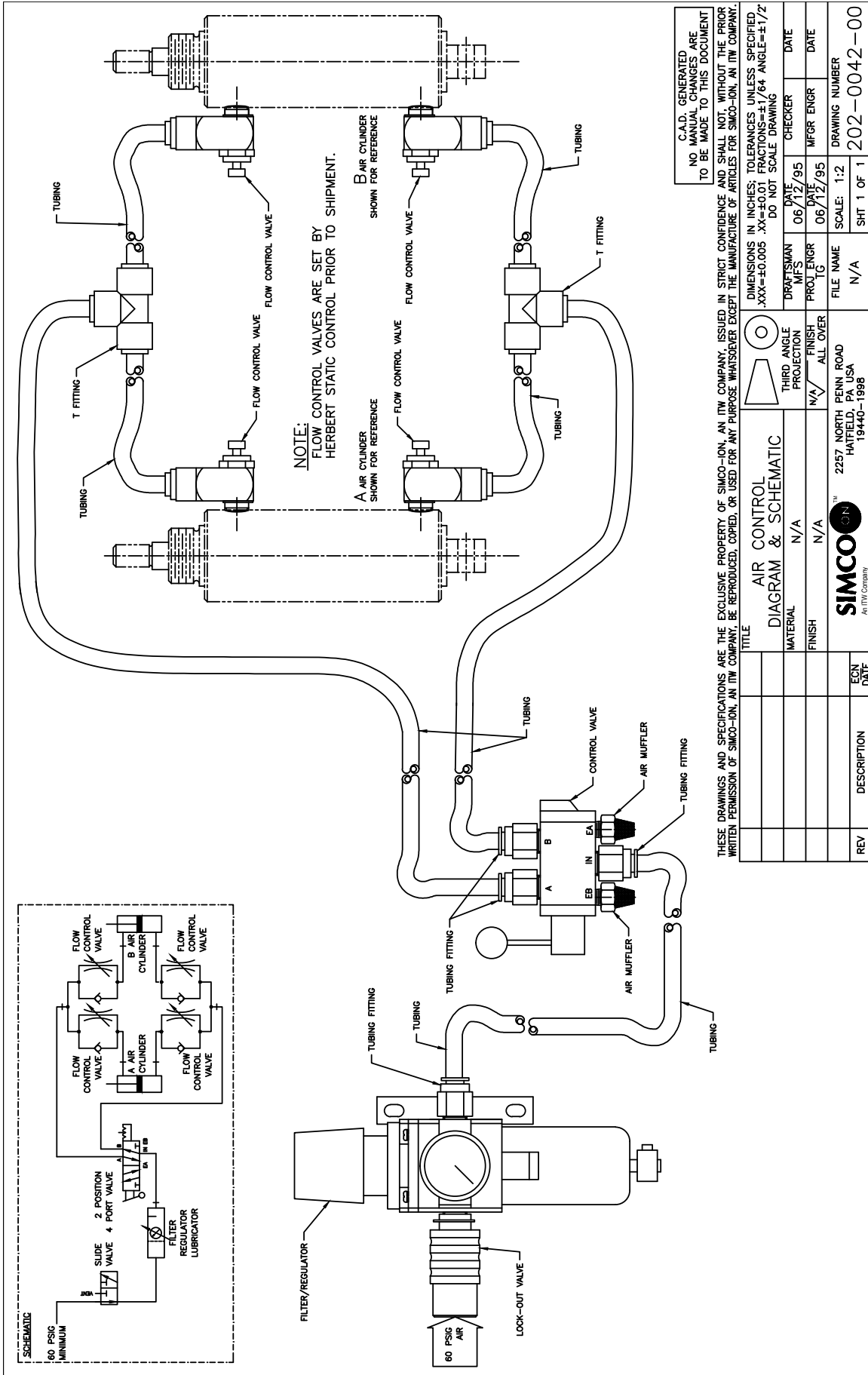

C.A.D. GENERATED
NO MANUAL CHANGES ARE
TO BE MADE TO THIS DOCUMENT

THESE DRAWINGS AND SPECIFICATIONS ARE THE EXCLUSIVE PROPERTY OF SIMCO-ION, AN ITW COMPANY, ISSUED IN STRICT CONFIDENCE AND SHALL NOT, WITHOUT THE PRIOR WRITTEN PERMISSION OF SIMCO-ION, AN ITW COMPANY, BE REPRODUCED, COPIED, OR USED FOR ANY PURPOSE WHATSOEVER EXCEPT THE MANUFACTURE OF ARTICLES FOR SIMCO-ION, AN ITW COMPANY.

DETAILED DIMENSIONS IN INCHES, TOLERANCES UNLESS SPECIFIED:
 .XX=±0.005 .XX=±0.01 FRACTIONS=±1/64 ANGLE=±1/2
 DO NOT SCALE DRAWING

DRAWN	DATE	CHECKER	DATE
MFS	06/12/95	MFGR ENGR	DATE
TC	06/12/95	PROJ ENGR	DATE
THIRD ANGLE PROJECTION		N/A ALL OVER	
MATERIAL		N/A	
FINISH		N/A	

TITLE	AIR CONTROL DIAGRAM & SCHEMATIC
-------	---------------------------------

REV	DESCRIPTION	EEN DATE

FILE NAME	N/A
SCALE	1:2
DRAWING NUMBER	202-0042-00
SHT 1 OF 1	

2237 NORTH PENN ROAD
 HAITFIELD, PA USA
 19440-1996

SIMCO
 An ITW Company

Simco-Ion

2257 North Penn Road

Hatfield, PA 19440

(215) 822-6401

(800) 203-3419

www.simco-ion.com

customerservice@simco-ion.com

© 2024 Simco-Ion Printed in the U.S.A.